

Thread milling

NOMENCLATURE

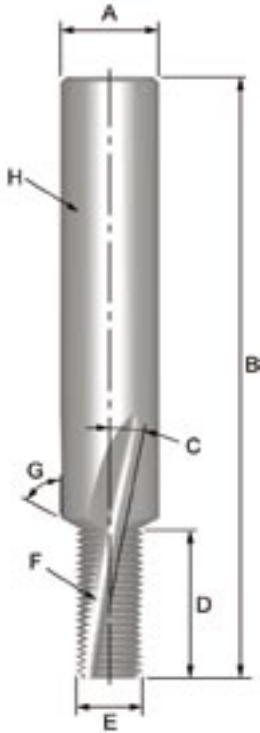

- A Shank Diameter
- B Overall Length
- C Helix Angle
- D Cutting Length
- E Thread Diameter
- F Flute
- G Chamfer Angle
- H Shank



- 1 Cutting Rake Angle
- 2 Web Diameter
- 3 Radial Thread Relief

GENERAL HINTS ON THREAD MILLING

Thread milling is a method of producing a thread with a milling operation.

To make this possible, you need a CNC-machine which can make helical paths, (run in 3 directions). Consult your manual or contact your machine supplier for information. You can also write your own sub-program for the thread milling operation.

1. Run the application in the Product Selector and you will get a suggestion of the thread milling cutter best suited for the application, with cutting data and a CNC program optimised for the application. The CNC program can be produced according to the most common systems, including DIN66025(ISO), Heidenhain, Fanuc and Siemens.
2. Use recommended drill sizes for the thread diameter, as for conventional taps.
3. For easy adjustments of the thread tolerance, always program with radius correction. Start value Rprg is printed on the cutter. If a tolerance is selected in the Product Selector you will also get a recommendation of how much to adjust the Rprg value.
4. Use a gauge to check the tolerance on the first thread and then regularly to get an indication if the radius needs to be corrected. The radius can normally be corrected 2-3 times before the thread milling cutter is worn out.
5. When dry machining is used, it is recommended to blow away the chips with compressed air.
6. When working with more difficult materials, it is recommended that the thread milling operation be done in 2 or 3 passes. The Product Selector gives you the choice of generating a CNC-program dividing the cut by a half or 1/3 (2 or 3 passes).

ADVANTAGES OF THREAD MILLING COMPARED TO CONVENTIONAL THREADING

- Thread milling gives increased reliability, namely:
 - Smaller chips.
 - Tolerance adjustments can be made using exact calculations.
 - Full thread to the bottom of the hole.
- Longer tool life.
- Suitable for most materials.
- The same cutter can be used for many diameters, as long as the pitch is the same.
- The same tool can be used both for left and right hand internal threads, and G can be used for both internal and external threads.
- Enables dry machining.
- The countersink on the metric tool makes it possible to chamfer.
- Conical threads with the possibility to chamfer with a superior quality and accuracy compared to conventional taps.

Thread milling

OTHER FACTS ABOUT THREAD MILLING

- Thread milling is a slow process and time savings are apparent on larger dimensions. However, the quality of finish and accuracy achieved can greatly compensate for the speed of the production process.
- Thread depth is limited to 2 x Diameter for metric and 1.5 x Diameter on Metric Fine and G.
- It is possible to regrind the cutter on the rake side (see regrinding section).

CHOOSING YOUR TOOL

All thread milling cutters have an Item Code based on the type, diameter (d_1) and the pitch (P). The item code is the number to use when ordering your tool. Always consult the Catalogue/Product Selector for correct thread dimension of tool.

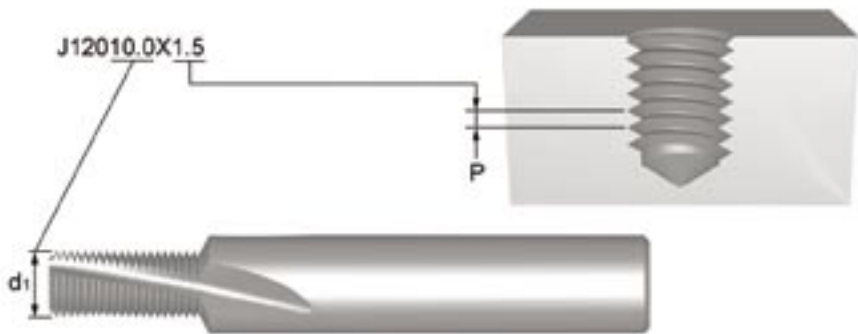

This thread milling cutter can be used for threads \geq M12x1.5 (M14x1.5, M16x1.5 etc)

PROGRAMMING WITH RPRG

For easy adjustment of the thread tolerance, always program with radius correction. The Rprg value is printed on the cutter and it is normally entered in the tool memory offset. The Rprg is a start value for new cutters.

Rprg is based on the theoretical Zero-line of the thread. This means that when you work with Rprg the thread is never too large but very tight, normally too tight. You have to add a small amount afterwards in order to find out the correct tolerance for your Nominal thread Diameter. Check with a gauge. If you use the Product Selector to generate the CNC-program, you will get a recommendation of how much to adjust the Rprg value to get the selected tolerance. Remember a smaller Rprg value gives a bigger nominal thread diameter.

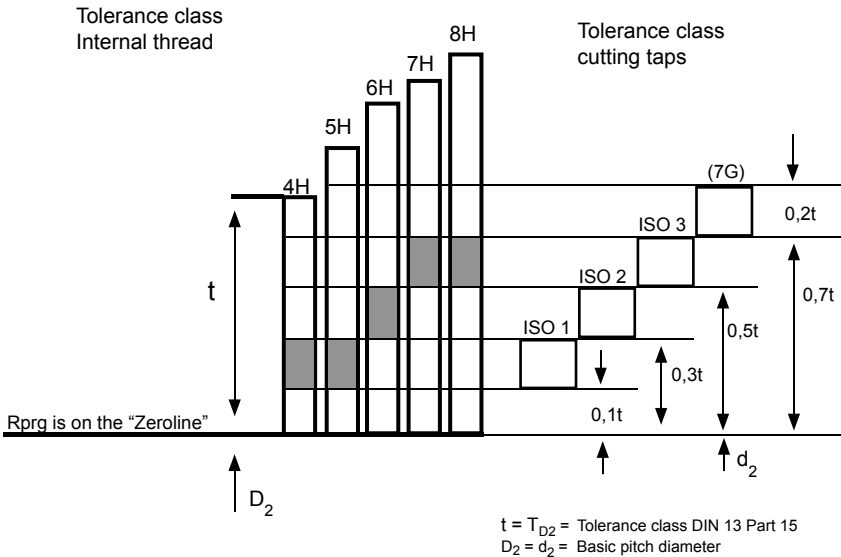

Thread milling

TROUBLE SHOOTING WHEN THREAD MILLING

Problem	Cause	Remedy
Short tool life	Wrong cutting data	Reduce speed/feed
	Instability	Check tool holder
	Rapid wear	Reduce speed
Broken cutter	Bad chip evacuation	Use compressed air, emulsion or internal coolant
	Load too big	Divide cut into 2 or 3 passes
		Reduce feed
Instability	Check/change tool holder	
Chipping	Instability	Check/change tool holder
	Wrong cutting data	Reduce speed/feed
	Load too big	Divide cut into 2 or 3 passes
Reduce feed		

For best tool life always use recommended CNC-program with correct soft entry into material. Check with the Product Selector.

Programming:

“I can’t find the program language for my CNC-machine in the Selector.”

– Many control systems can be switched over to DIN/ISO when you are doing the thread milling path. Check with the manual.

“It is the first time I have used a thread milling cutter and when I run the thread mill above the workpiece, it looks like it will create a much too large a thread.”

- The control system does not read that you have moved the centre of the tool to the contour (M41). Check that correct Rprg-value is in the tool-memory offset, and that the correct tool is linked to this Rprg-value.

